

Introduction to Computing (SE-101)

Ali Ameer Gondal

Assistant Professor

Software Engineering Department

University of Engineering & Technology

Taxila, Pakistan

ali.ameer@uettaxila.edu.pk

Questions from previous lecture?

Processor & Storage Devices

Lecture # 6

27th Dec. 2011

Part-I

Processors

Processor (CPU)

- The computer's primary processing hardware, which interprets and executes program instructions and manages the functions of input, output, and storage devices

Architecture

- A processor's performance is dictated by its internal design, or architecture
- Architecture
 - Determines
 - No. of transistors
 - Location of CPU parts
 - Bit size
 - Number of registers

Microcomputer Processors

- Intel
 - Leading manufacturer of processors
 - Intel 4004 was worlds first microprocessor
 - IBM PC powered by Intel 8086
 - Current processors
 - Centrino
 - Pentium
 - Xeon
 - Core 2
 - Core i3,i5, i7
 - Atom



Microcomputer Processors

- Advanced Micro Devices (AMD)
 - Main competitor to Intel
 - Originally produced budget products
 - Current products outperform Intel
 - Current processors
 - Sempron
 - Athlon FX 64
 - Athlon XP



Microcomputer Processors

- Freescale
 - A subsidiary of Motorola
 - Co-developed the Apple G4 PowerPC
 - Currently focuses on the Linux market



Microcomputer Processors

- IBM
 - Historically manufactured mainframes
 - Partnered with Apple to develop G5
 - First consumer 64 bit chip
 - Pixar studios used G5



Comparing Processors

- Clock speed
- Size of cache
- Number of registers
- Word size
- Speed of Front side bus

Advanced Processor Topics

- RISC processors
 - Reduced Instruction Set Computing
 - Smaller instruction sets
 - May process data faster
 - PowerPC and G5



Working on 50 MHz

Advanced Processor Topics

- Parallel Processing
 - Multiple processors in a system
 - Symmetric Multiple Processing
 - Number of processors is a power of 2
 - Massively Parallel Processing
 - Thousands of processors
 - Mainframes and super computers

Extending The Processors Power

- Standard computer ports
 - Keyboard and mouse ports
 - USB ports
 - Parallel
 - Network
 - Modem
 - Audio
 - Serial
 - Video

Standard Computer Ports



Extending The Processors Power

- Serial and parallel ports
 - Connect to printers or modems
 - Parallel ports move bits simultaneously
 - Made of 8 – 32 wires
 - Internal busses are parallel
 - Serial ports move one bit
 - Lower data flow than parallel
 - Requires control wires
 - UART converts from serial to parallel

Serial Communications

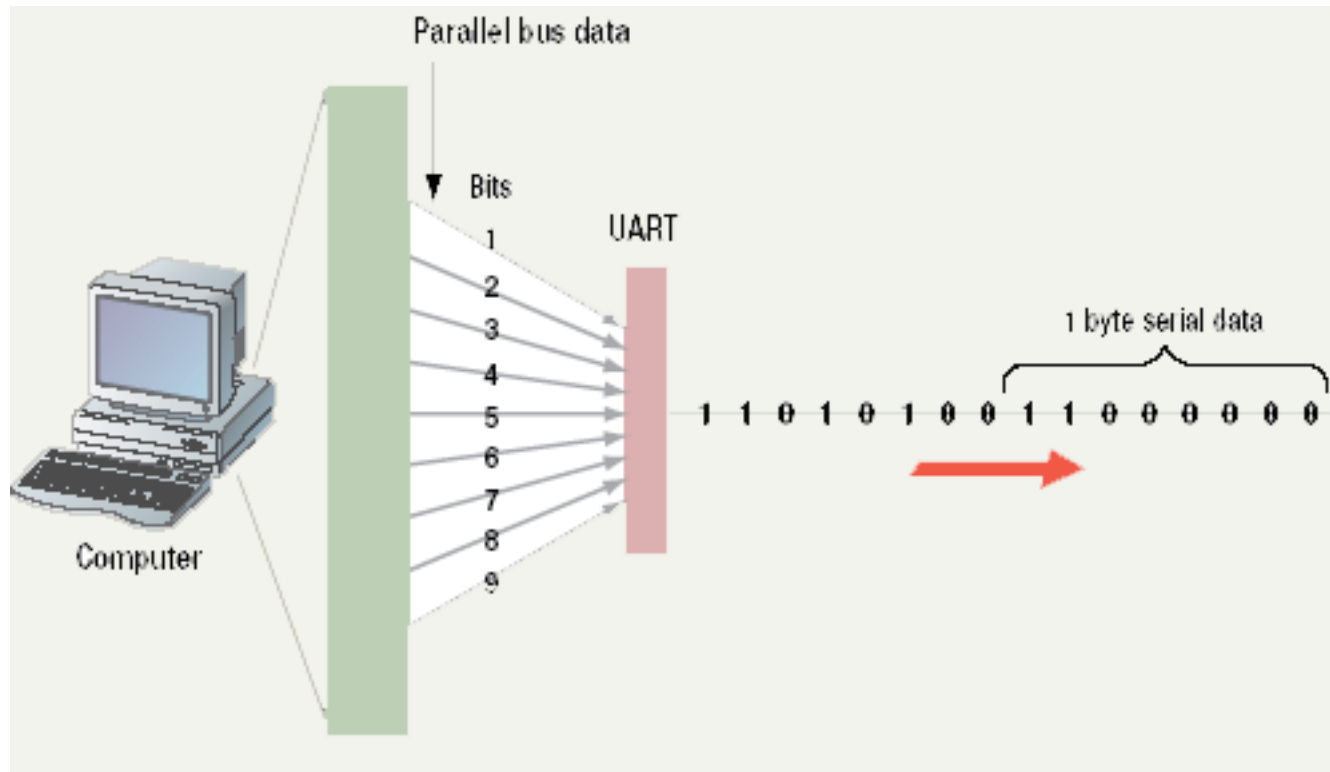

Parallel Communications

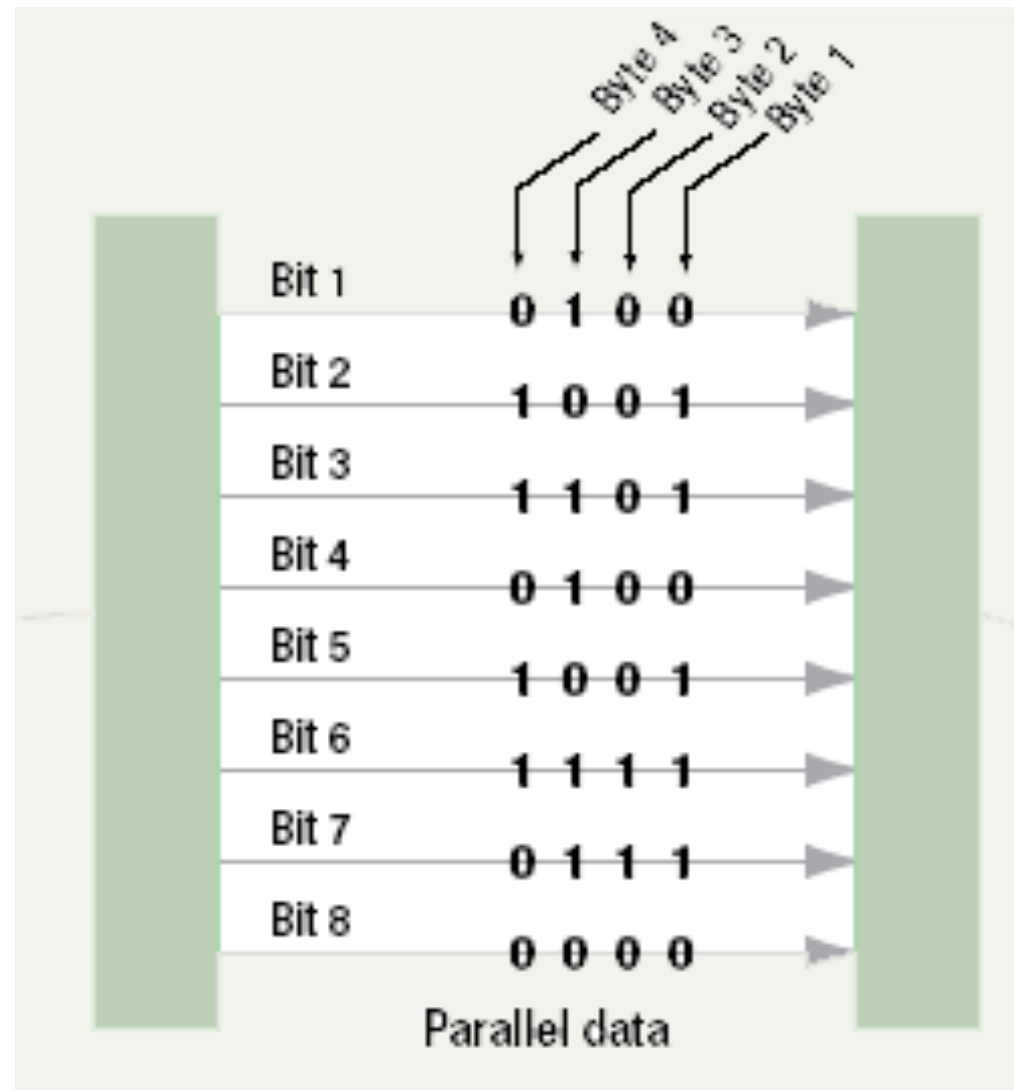

Extending The Processors Power

- SCSI
 - Small Computer System Interface
 - Supports dozens of devices
 - External devices daisy chain
 - Fast hard drives and CD-ROMs

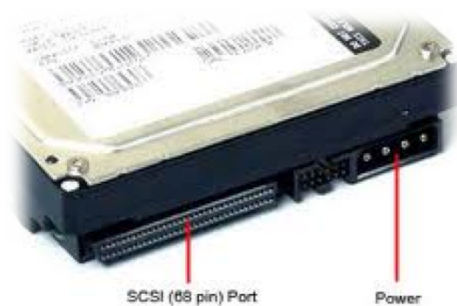

Extending The Processors Power

- USB
 - Universal Serial Bus
 - Most popular external bus
 - Supports up to 127 devices
 - Hot swappable



Extending the Processors Power

- FireWire
 - IEEE 1394
 - Cameras and video equipment
 - Hot swappable
 - Port is very expensive



Extending the Processors Power

- Expansion slots and boards
 - Allows users to configure the machine
 - Slots allow the addition of new devices
 - Computer must be off before inserting



Extending the Processors Power

- PC Cards
 - Expansion bus for laptops
 - PCMCIA
 - Hot swappable
 - Small card size
 - Three types, I, II and III
 - Type II is most common



PC Cards

USB, Firewire,
eSATA, Internet, etc.
adapters



ATA flash
PC card



Panasonic P2
card



Flash memory
adapters



AirCard
(wireless PC card)



Amtron PCD-TP-110CS
in drive bay



Introducing
3G "Wireless Broadband" in Pakistan

THERE'S NO END TO IT



3.1 Mbps.



Wireless | Affordable | Unlimited



Extending the Processors Power

- Plug and play

- Makes it easier to install hardware via an existing port or expansion slot
- New hardware detected automatically
- Prompts to install drivers
- Non-technical users can install devices

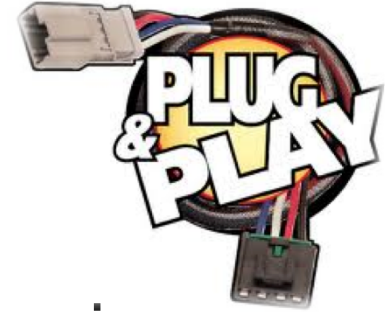

Plug and play Devices



Part-II

Storage Devices

Storage Involves Two Processes

- Writing data
- Reading data

Storage Media

- The materials on which data is stored
- E.g. Diskette

Storage Devices

- The hardware components that write data to, and read data from, storage media
- E.g., Diskette drive

Two Categories of Storage Technology

- Magnetic storage
- Optical storage

Magnetic Storage

- Diskettes
- Hard disks
- High-capacity floppy disks
- Magnetic tape

Optical Storage

- Compact Disk Read-Only Memory (CD-ROM)
- CD-Recordable (CD-R)/CD-ReWritable (CD-RW)
- Digital Video Disk Read-Only Memory (DVD-ROM)
- DVD Recordable (DVD-R/DVD ReWritable (DVD-RW)
- Photo CD

Magnetism Allows Data Storage

- Hard disks, diskettes, high-capacity floppy disks and tapes have a magnetic coating on their surface that enables each medium to store data.

Preparing Disks for Storage

- Formatting or initializing prepares disks for storage, magnetically mapping the disk's surface.

Formatted Disks Have Three Sections

- Main sections, called Tracks
- Track subsections, called Sectors
- Groups of sectors, called Clusters

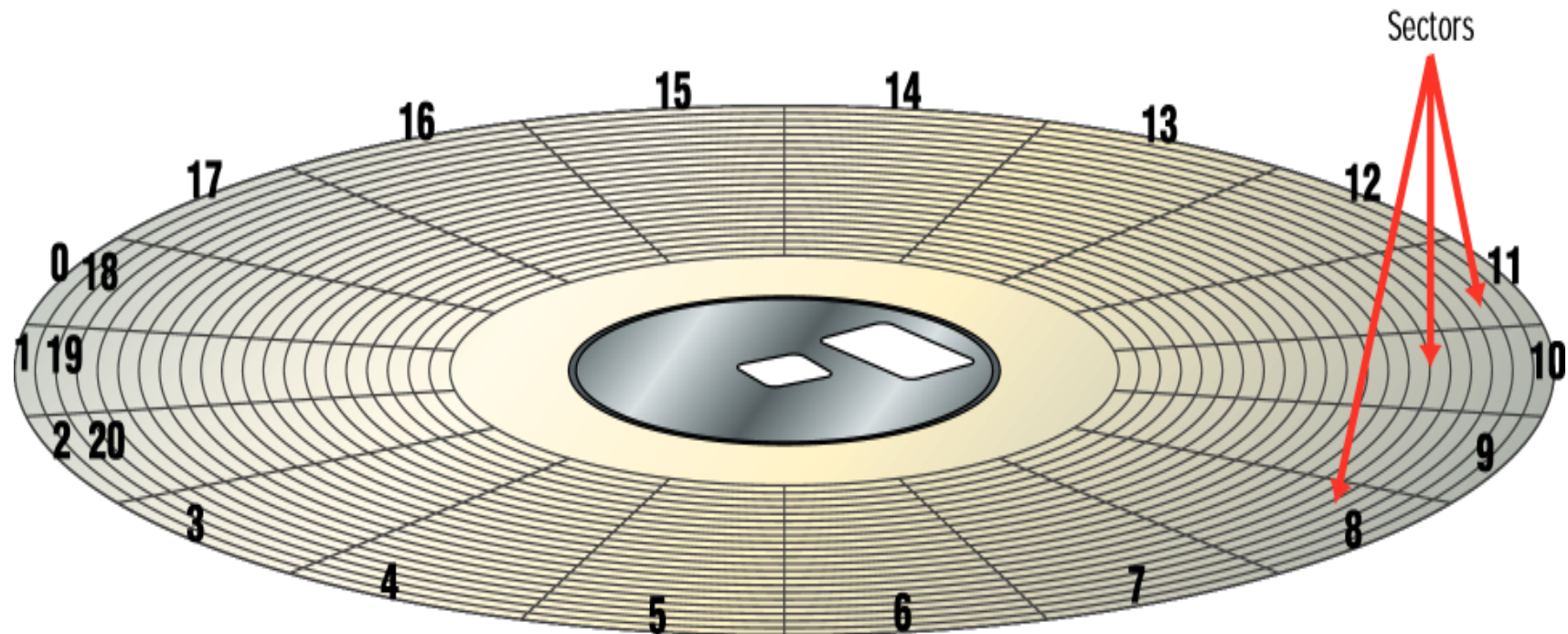

Logical Format

- A logical format is the labeling of tracks and sectors

The Logical Format has Four Disk Areas

- Master boot record
- File allocation table
- Root folder
- Data area

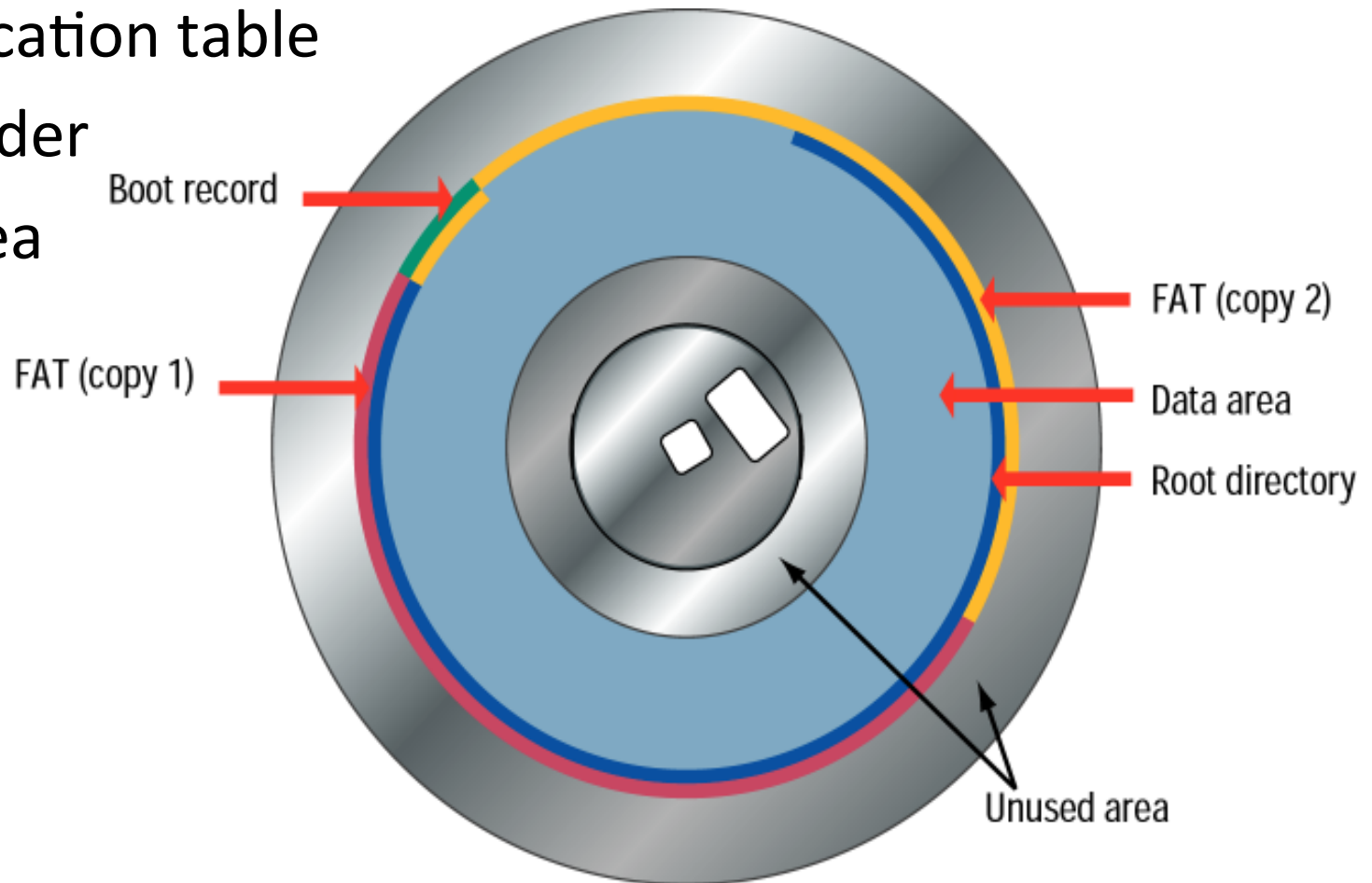

Master Boot Record

- This program determines whether the disk contains the basic components of an operating system necessary to run successfully

File Allocation Table (FAT)

- A log created during the logical formatting process that records the location of each file and status of each sector on the disk

Root Folder

- The top folder or directory in the disk's folder hierarchy

Data Area

- Where data or program files are stored

3.5-inch Diskettes (Floppy Disks)

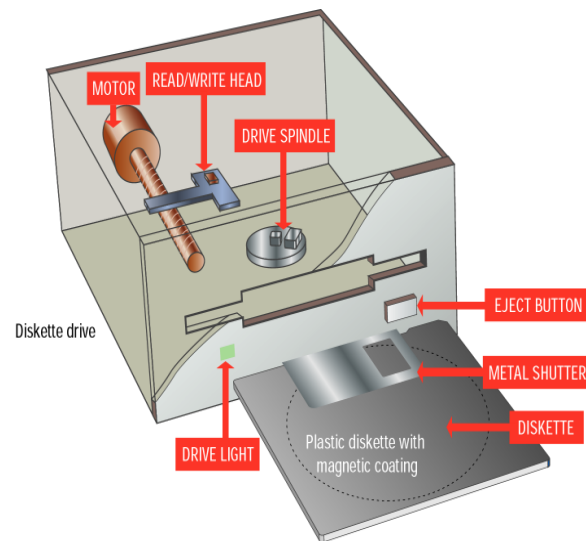

Spin rate: 300 revolutions per minute (rpm)

High density (HD) disks more common today than older, double density (DD) disks

- Storage Capacity of HD disks is 1.44 MB

Hard Disks

- Spin rate: from 3,600 to 15,000 rpm
- Storage capacity ranges from several hundred MB to more than 80 GB

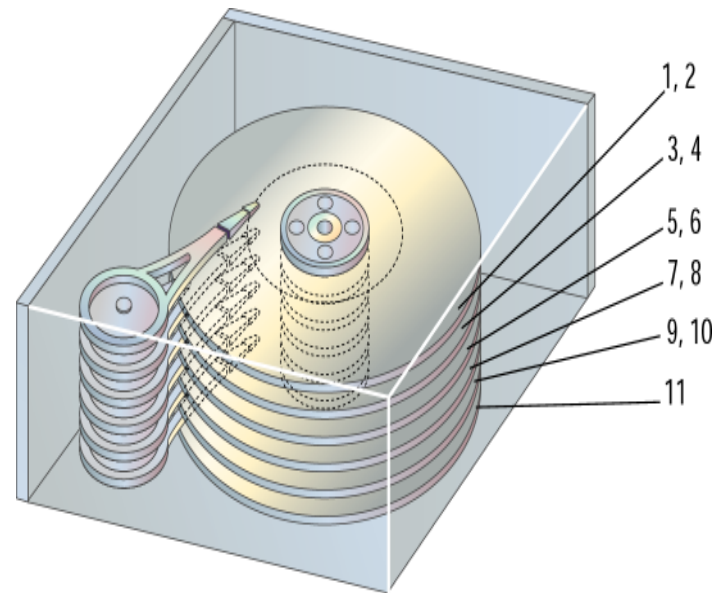

Removable High-Capacity Magnetic Disks

- Combines the speed and capacity of a hard disk with the portability of a diskette

Three Kinds of Removable High-Capacity Magnetic Disks

- High-Capacity Floppy Disks
- Hot-Swappable Hard Disks
- Disk Cartridges

Tape Drives

- Commonly used for hard disk backup



PC Cards

- Used to connect new components like memory and expanding storage capacity to a computer

Optical Storage Devices

- Data is stored on a reflective surface so it can be read by a beam of laser light.

Two Kinds of Optical Storage Devices

- CD-ROM (compact disk read-only memory)
- DVD-ROM (digital video disk read-only memory)

Compact Disk (CD)

- Standard CD's store 650 MB of data or 70 minutes of audio
- New generation CD's hold 700 MB of data or 80 minutes of audio
- CD-ROM drives are slower than hard disk drives
- CD-ROM speed is expressed in multiples and range from 2x to 75x

Digital Video Disk (DVD)

- Storage capacity ranges from 9.4 GB to 17 GB

Recordable Optical Technologies

- CD-Recordable (CD-R)
- CD-ReWritable (CD-RW)
- PhotoCD
- DVD-Recordable (DVD-R)
- DVD-RAM

Emerging Storage Technologies

- FMD-ROM
- Smart Cards
- Holographic memory

Questions?

If you have any query please feel free to ask

Phone: +92-51-9047-590

Email: ali.ameer@uettaxila.edu.pk

University of Engineering & Technology, Taxila Pakistan

Reference

- The slides were taken from the book:
 - “Introduction to computing” by Peter Norton